



USER MANUAL EN

Edition: 1 from 27.04.2023
Supersedes edition:

Power supplies DING2 series

v1.0

Switch mode power supply units with battery backup for a DIN rail Grade 2

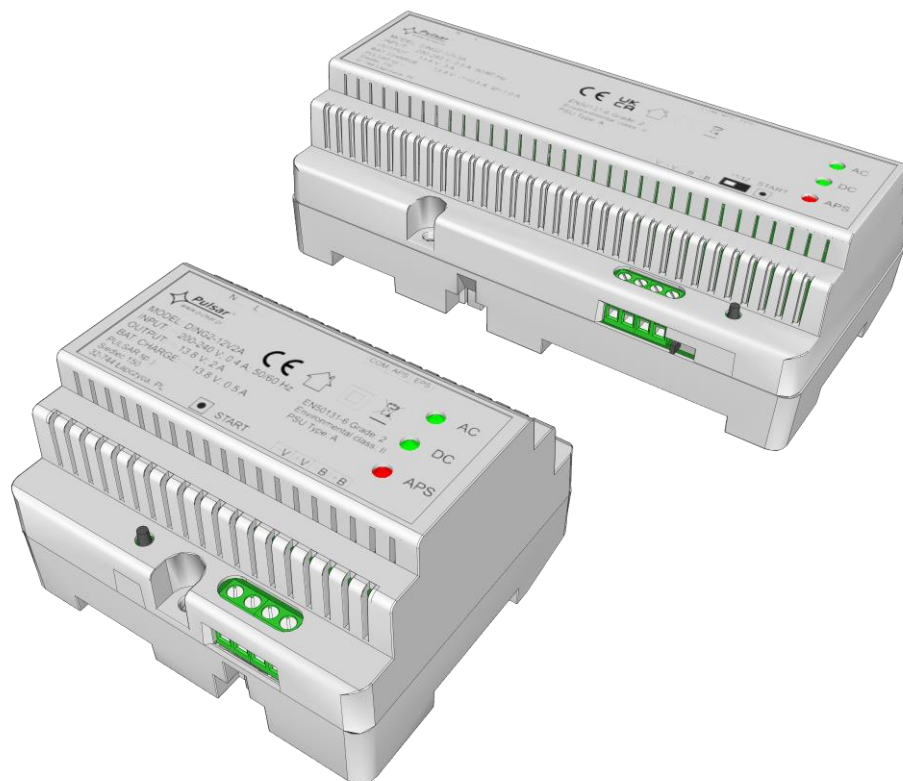

Features:

- compliance with norm EN50131-6:2017 in grade 1, 2 and II environment class
- compliance with norm (KD) EN60839-11-2:2015+AC:2015 standard and I environment class
- mains supply of ~200 – 240 V
- DC 13,8 V or 27,6 V uninterruptible power supply
- available versions with current efficiencies
13,8 V: 2A/3A/5A
27,6 V: 2A/3A
- high efficiency (up to 90%)
- battery charging current jumper selectable (selected models)
- deep discharge battery protection (UVP)
- function START allows running PSU from battery circuit
- LED optical indication
- dynamic battery test
- battery circuit continuity control
- battery voltage control
- EPS technical output indicating power loss – OC type
- APS technical output indicating battery failure – OC type
- battery charging and maintenance control
- battery output protection against short circuit and reverse connection
- protections:
 - SCP short circuit protection
 - OLP overload protection
 - OVP overvoltage protection
 - surge protection
- warranty – 2 years from production date

TABLE OF CONTENTS:

1. Technical description.
 - 1.1. General description.
 - 1.2. Block diagram.
 - 1.3. Description of PSU components and connectors.
 - 1.4. Specifications.
2. Installation.
 - 2.1. Requirements.
 - 2.2. Installation procedure.
3. Operating status indication.
 - 3.1. Optical indication.
 - 3.2. Technical outputs
 - 3.3. Technical outputs relay type.
 - 3.4. Standby time.
 - 3.5. Battery charging time.
 - 3.6. Running PSU on battery backup.
4. Maintenance.

1. Technical description.**1.1. General description.**

Power supply modules are intended for installation in an additional enclosure. In order to meet the requirements of IDS and AC standards, enclosure must be designed in accordance to security level with which compliance is established.

Buffer power supply is designed in accordance with the requirements of (I&HAS) EN50131-6:2017, grade 1, 2 and II environment class and (KD) EN60839-11-2:2015+AC:2015 standard and I environment class. Power supplies units are intended for an uninterrupted supply of I&HAS and KD devices requiring stabilized voltage of 12 or 24 V DC ($\pm 15\%$).

Displaying parameters of power supply:

PSU's name	Output voltage	Charging current	Total output current with charging
DING2-12V2A	13,8 V	0,5 A	2,5 A
DING2-12V3A	13,8 V	0,5 / 1 A	3,5 A
DING2-12V5A	13,8 V	1 / 2 A	5 A
DING2-24V2A	27,6 V	0,5 / 1 A	2 A
DING2-24V3A	27,6 V	0,5 / 1 A	3 A

In case of power failure, a battery back-up is activated immediately.

Depending on a required protection level of the alarm system in the installation place, the PSU efficiency and the battery charging current should be set as follows:

Grade 1, 2 - standby time 12h:

The 12h standby output current can be calculated from the formula:

$$I_{WY} = Q_{AKU} / 12 - I_z$$

where:

Q_{AKU} – minimum battery capacity [Ah]

I_z – PSU current consumption (including optional modules) [A] (Table 2)



PSU module should be configured properly, depending on application, to work in burglary and assault signalling systems or access control. For this purpose, appropriate charging current should be selected (taking into account battery capacity and required charging time).

1.2. Block diagram (Fig. 1).

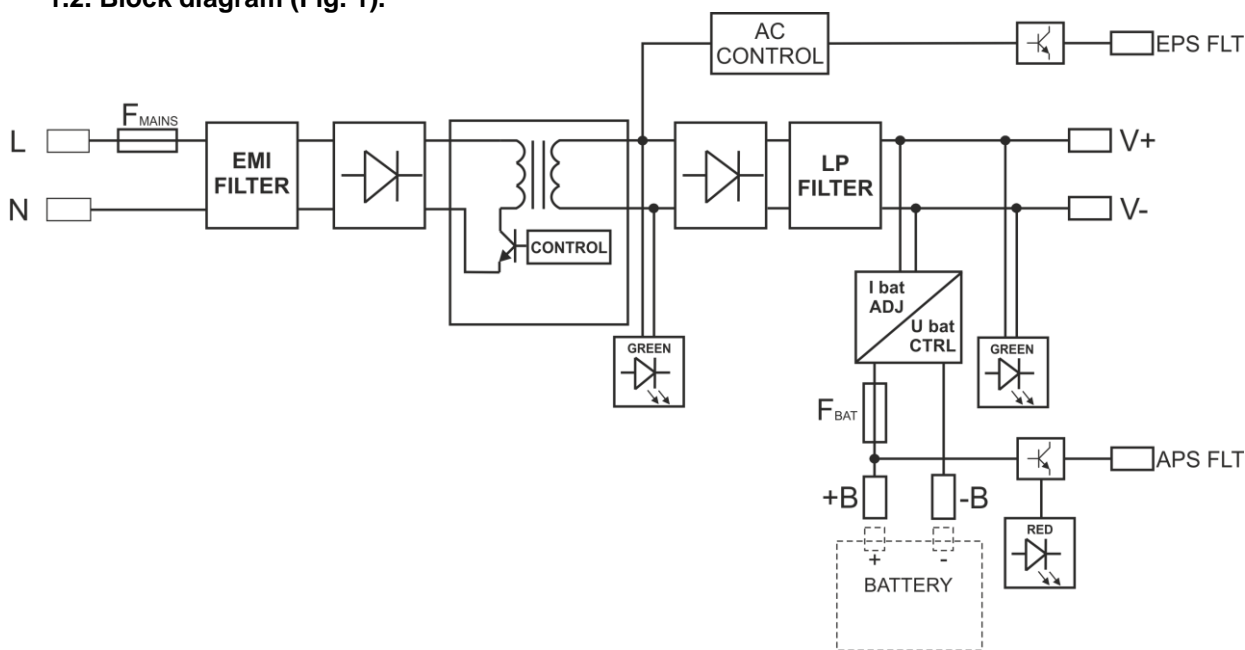



Fig.1. Block diagram of PSU.

1.3. Description of PSU components and connectors.

Table 1. Elements and connectors PSU (see Fig. 2a, 2b).

Element no.	Description
[1]	Optical signalization (see section 3.1.)
[2]	Selection jumper for charging current: Power supply units: 12V3A; 12V5A; 24V2A; 24V3A <ul style="list-style-type: none"> • I_{BAT} =  I_{BAT} = I1 • I_{BAT} =  I_{BAT} = I2
[3]	START - button (launching from battery)
[4]	Output of PSU (V+, V-)
[5]	Battery terminals (B+, B-)
[6]	APS – technical output of battery failure
[7]	EPS – technical output of AC network absence indication
[8]	L-N power supply connector 230 V AC

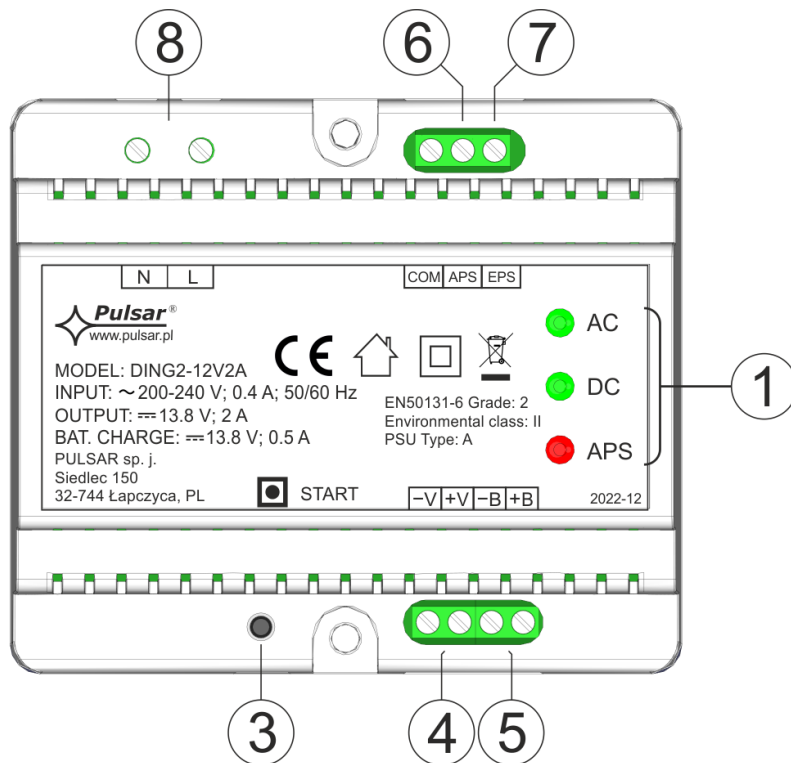

Fig. 2a. View of power supply module (12V2A model)

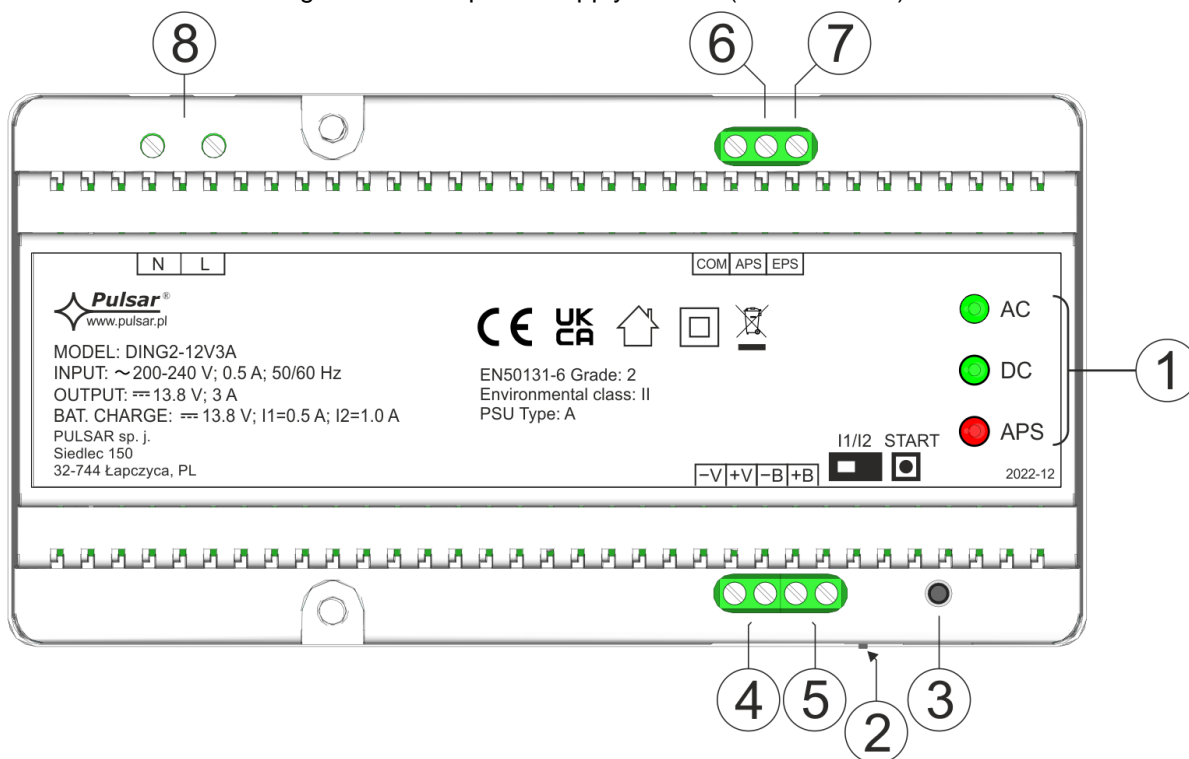

Fig. 2b. View of power supply module (12V3A, 12V5A, 24V2A, 24V3A models)

1.4. Specifications:

- electrical parameters (Tab. 2)
- operation safety (Tab. 3)
- operating parameters (Tab. 4)

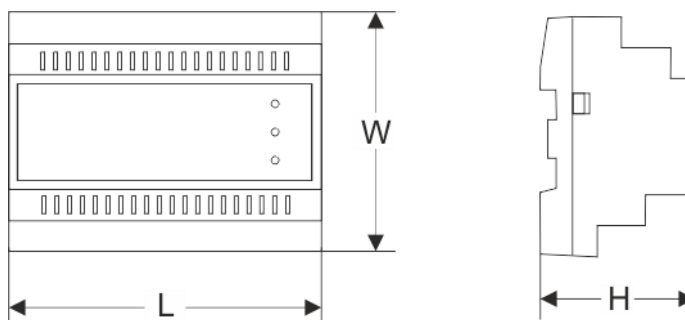

Table 2. Specifications.

Model	DING2-12V2A	DING2-12V3A	DING2-12V5A	DING2-24V2A	DING2-24V3A
PSU type EN50131-6	A, Grade 1,2, II environmental class				
Supply voltage	~ 200 - 240 V				
Current consumption	0,4 A	0,5 A	0,7 A	0,6 A	0,9 A
Power frequency	50/60 Hz				
Inrush current	40 A				
Output power PSU	35 W	48 W	69 W	55 W	83 W
Total output current with charging	2,5 A	3,5 A	5 A	2 A	3 A
Efficiency	86 %	90%	90%	89%	90%
Output voltage	11 - 13,8 V – buffer operation 10 - 13,8 V – battery-assisted operation			22 - 27,6 V – buffer operation 20 - 27,6 V – battery-assisted operation	
Ripple voltage (max.)	100 mV p-p				
Current consumption by PSU systems during battery-assisted operation	20 mA	20 mA	20 mA	20 mA	20 mA
Battery capacity	7 – 9 Ah	7 – 20 Ah	7 – 40 Ah	7 – 17 Ah	7 – 17 Ah
Charging current (jumper selectable)	I1: 0,5 A	I1: 0,5 A I2: 1 A	I1: 1 A I2: 2 A	I1: 0,5 A I2: 1 A	I1: 0,5 A I2: 1 A
Net/gross weight	0,26/0,31 [kg]	0,36/0,42 [kg]	0,40/0,46 [kg]	0,36/0,43 [kg]	0,40/0,47 [kg]
Battery circuit protection SCP and reverse polarity connection	- polymer fuse (returnable)				
Overload protection (OLP)	105-150% PSU power, automatically recovered				
Over voltage protection (OVP)	>19 V (after running, disconnect PSU for about 1 minute)			>37 V (after running, disconnect PSU for about 1 minute)	
Deep discharge battery protection (UVP)	U<9,5 V (± 5%) – disconnection of battery circuit			U<18 V (± 5%) – disconnection of battery circuit	
Optical indication	- LED indicators on power supply's cover (see section 3.1)				
EPS output	OC type: 50 mA max. normal status: L (0V) level, failure: hi-Z level (time lag: 30s)				
APS output	OC type: 50 mA max. normal status: L (0V) level, failure: hi-Z level				
Fuses: - F_{BAT}	PTC 3A/30V	PTC 4A/30V	PTC 5A/30V	PTC 3A/30V	PTC 4A/30V
Enclosure dimensions (LxWxH) [±2mm]	106x91x60	176x91x60	176x91x60	176x91x60	176x91x60
Terminals: Mains supply: Outputs: Battery outputs:	0,5 – 2,5 mm ² (AWG 26 – 12)				
Notes:	Battery wires 6,3F – 45cm, angle muffs ML062				
	Convictional cooling				

Table 3. Operation safety.

Protection class EN 62368-1	II
Protection grade EN 60529	IP20
Electrical strength of insulation: - between input and output circuits of the PSU - between input circuit and protection circuit - between output circuit and protection circuit	4000 V DC min. 2500 V DC min. 500 V DC min.
Insulation resistance: - between input circuit and output or protection circuit	100 MΩ, 500 V DC

Table 4. Operating parameters.

Environment class EN 50131-6	II
Environment class EN 60839-11-2	I (first)
Operating temperature	-10°C...+40°C
Storage temperature	-20°C...+60°C
Relative humidity	20%...90%, without condensation
Vibrations during operation	unacceptable
Impulse waves during operation	unacceptable
Direct insolation	unacceptable
Vibrations and impulse waves during transport	According to PN-83/T-42106

2. Installation.

2.1 Requirements.



Power supply modules are intended for installation in an additional enclosure. In order to meet the requirements of IDS and AC standards, enclosure must be designed in accordance to security level with which compliance is established.

Buffer power supply is designed to be installed only by qualified installer with necessary permits and authorisations (required in installation country) to connect (interfere) with the 230 V mains supply. The PSU shall work in a vertical position that guarantees sufficient convectional air-flow through ventilating holes of the enclosure. The device be mounted in a metal enclosure (cabinet) in a vertical position so as to ensure free, convection air flow through the vents. In order to meet the EU requirements, follow the guidelines on: power supply, enclosures and shielding: - according to application.

As the PSU is designed for a continuous operation and is not equipped with a power-switch, therefore an appropriate overload protection shall be guaranteed in the power supply circuit. Moreover, the user shall be informed about the method of unplugging (usually through assigning an appropriate fuse in the fuse-box). The electrical system shall follow valid standards and regulations.

2.2 Installation procedure.

**CAUTION!**

Before installation, make sure that the voltage in the 230 V power-supply circuit is cut off. To switch off power use an external switch in which the distance between the contacts of all poles in the disconnection state is not less than 3mm.

It is required to install an installation switch with a nominal current of 6 A in the power supply circuits outside the power supply unit.

1. Mount the PSU in a selected location and connect the wires.
2. Connect power cables (~230 V) to L-N clips of PSU. Use a two-core cable. Wires should be deisolated to a length of 7mm.

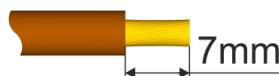

3. If needed, connect the device cables to the technical outputs:
 - EPS; technical output indicating AC power failure
 - APS; technical output indicating battery failure
4. Connect equipment to the appropriate output terminals of power supply (positive connector +V, negative connector -V)
5. Use the I_{BAT} jumper to set the maximum battery charging current, taking into account the battery parameters and required charging time.
6. Mount the battery in the battery compartment of the enclosure. Connect the batteries with the PSU paying special attention to the correct polarity and type of connections (Fig. 3):

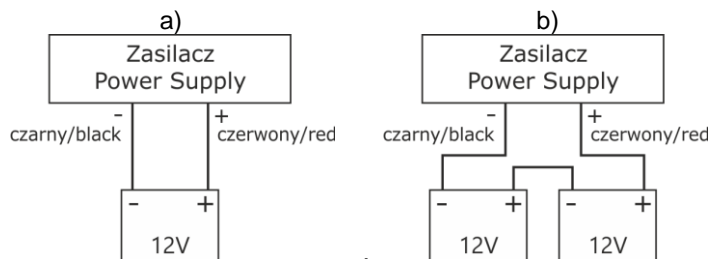

Fig. 3 Connecting batteries depending on voltage version of power supply:
 a) version 12V, b) version 24V.

7. Switch on the 230 V supply. LEDs on the PCB of power supply should light (see section 3.1). After installing and checking proper working, the enclosure can be closed.

Output voltage of the PSU, without load $U = 13,8 (27,6) \text{ V DC}$.

During battery charge, voltage can amount to $U = 11 - 13,8 (22 - 27,6) \text{ V DC}$.

8. Run the PSU test: check the LED and acoustic indication (Tab. 7), technical output; through:
 - **cutting off the 230 V current:** LED AC (Fig. 2 level 1), EPS technical output after time 30s
 - **battery disconnection:** optical indication, APS technical output – after a battery test have been (~3min).

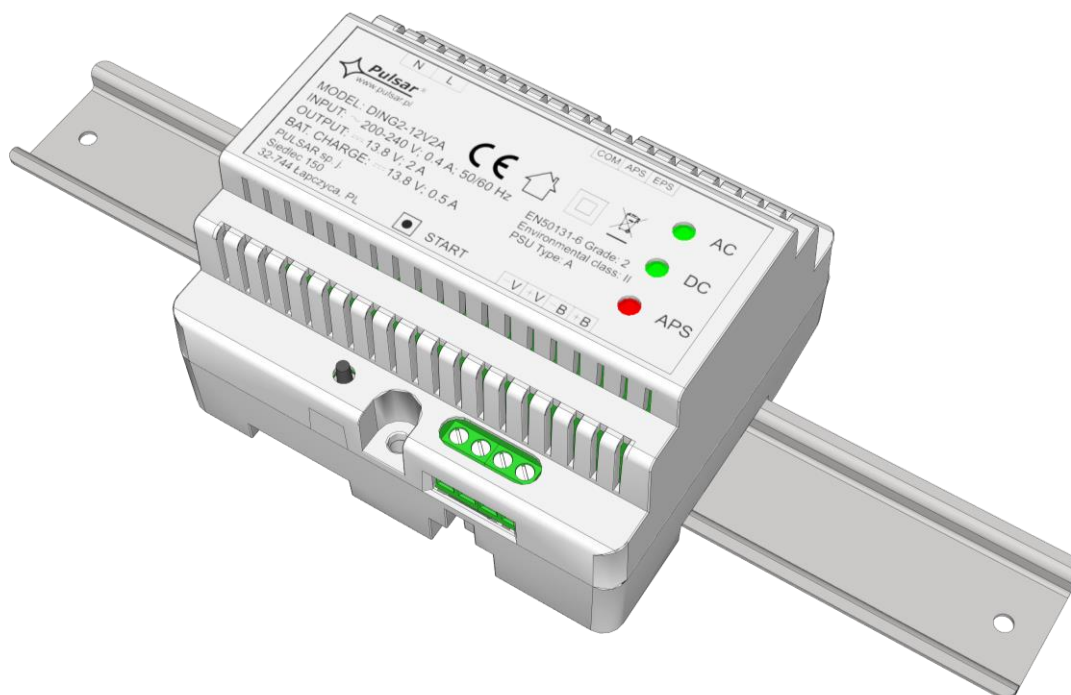

Fig. 4. Example of installation

3. Operating status indication.

The power supply unit features LED status indication

3.1 Optical indication.

The power supply is equipped with LEDs located on the cover of the power supply module, indicating the operating status:



Green LED AC:

- on – PSU is supplied with 230 V
- off – no 230 V power, battery-assisted operation



Green LED DC:

- on – presence of DC voltage in the output of the PSU
- off – no voltage in the output of the PSU



Red LED APS:

- off – no failure
- on – indicates battery failure status

3.2 Technical outputs.

The PSU is equipped with indication outputs:

- **EPS FLT - technical output indicating 230 V power failure.**

The output indicates 230 V power failure. In case of power failure, contacts of relay change over after about 30 seconds.

- **APS FLT - output indicating battery failure.**

The output indicates the PSU failure. In case of failure, contacts of relay change over.

PSU failure can be caused by the following events:

- defective or low battery
- battery fuse failure
- no continuity in the battery circuit
- battery voltage below 11,5 (23) V during battery-assisted operation

A battery failure is detected within a maximum of 3 minutes - after each battery test

The power supply technical outputs are open collector (OC) type, as shown schematically below.

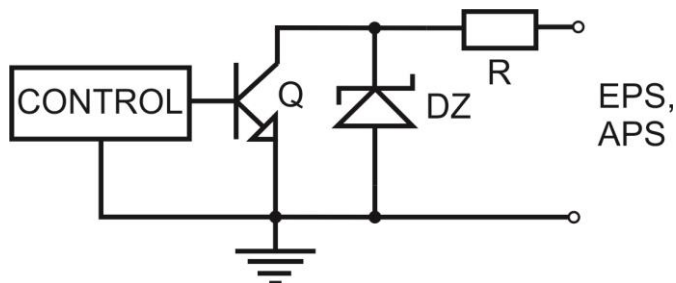

Fig. 5. Electrical diagram of OC outputs.

3.3 Technical outputs relay type

If OC type outputs are not sufficient to control unit, it is possible to use AWZ642 relay module changing technical outputs of OC type to relay type.

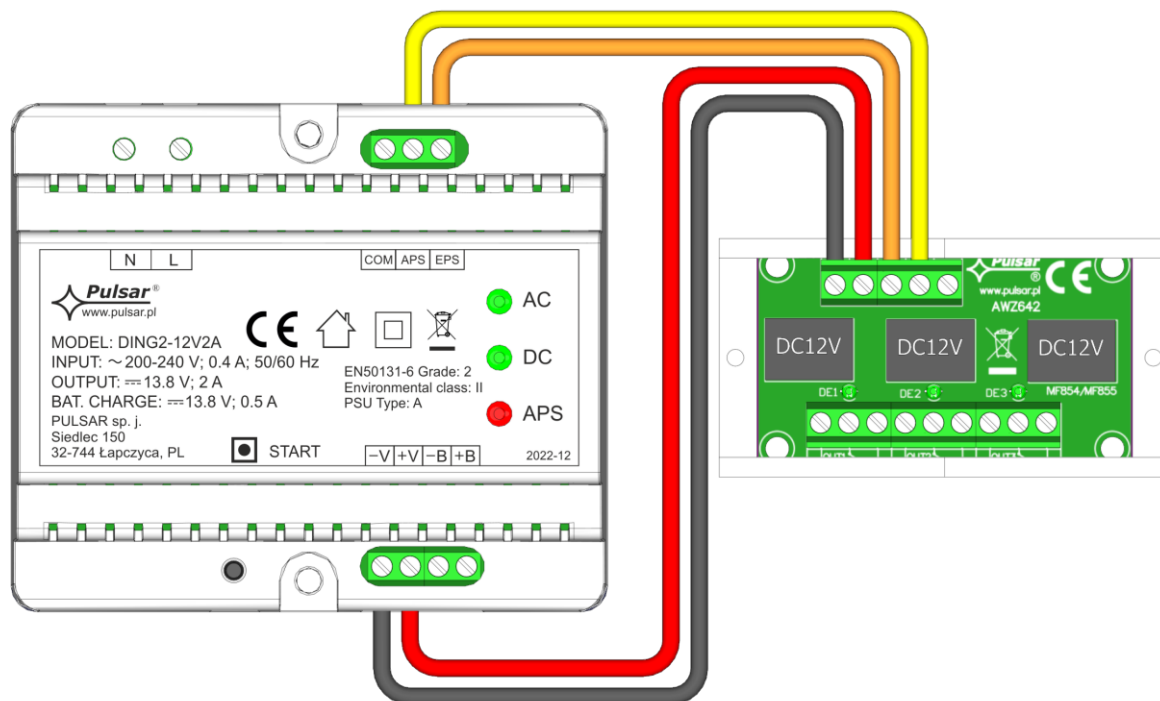

Fig. 6. The diagram of connecting the AWZ642 module.

3.4 Standby time.

Battery-assisted operating depends on battery capacity, charging level and load current. To maintain an appropriate standby time, Required battery capacity can be calculated using following formula:

$$Q_{AKU} = \text{Standby Period} * (I_{WY} + I_z)$$

where:

Q_{AKU} – minimum battery capacity [Ah]

I_{WY} – power supplies output current (drawing by the load)

I_z – PSU current consumption (including optional modules) [A] (Table 3)

3.5 Battery charging time.

PSU has a battery circuit charged with direct current. Current selection is done with use of the I_{BAT} jumpers. Table below shows how long does it take to charge a (fully discharged) battery up to min. 80% of its nominal capacity.

Table 5. Approximate battery charging time up to the capacity of 80%.

Battery	Charging current		
	0,5 A	1 A	2 A
7Ah	13h	7h	-
17Ah	31h	16h	8h
28Ah	-	26h	13h
40Ah	-	36h	18h

3.6 Running PSU on battery backup.

Power supply allows you to run on battery backup when necessary. To do this, press the START button on the cover of the power supply module.

4. Maintenance.

Any and all maintenance operations may be performed following the disconnection of the PSU from the power supply network. The PSU does not require performing any specific maintenance measures, however, in the case of significant dust rate, its interior is recommended to be cleaned with compressed air.

	<p>WEEE LABEL</p> <p>Waste electrical and electronic equipment must not be disposed of with normal household waste. According to European Union WEEE Directive, waste electrical and electronic equipment should be disposed of separately from normal household waste.</p>
---	---

Pulsar sp. j.

Siedlec 150,
32-744 Łapczyca, Poland
Tel. (+48) 14-610-19-45
e-mail: sales@pulsar.pl
[http:// www.pulsar.pl](http://www.pulsar.pl)

